

USER GUIDE



Responsiv™ Blink'n'Dim Adapter for 0-10V Control

Your Responsiv™ Blink'n'Dim adapter enables convenient, reliable, wide-range and flicker-free dimming for light fixtures that are dimmable by a 0-10V control signal.

The adapter generates a 0-10V control signal within or near your fixture. With the adapter, there is no need to run a 0-10V control cable between your fixture and a remote dimming control location.

Replace any existing dimmer with a switch. Traditional dimmers cause flickering and buzzing of 0-10V fixtures. Your ordinary light switch controls the adapter with simple Blink'n'Dim commands. If lights are controlled by multiple switches, each switch will have dimming capability.

A single adapter may be connected to the 0-10V control inputs of several fixtures for simultaneous dimming. Alternatively, multiple adapters may simultaneously dim multiple fixtures operated by a common power switch.

INSTALLATION

Your adapter and its associated power supply can be mounted in any convenient location within or near your light fixture. Avoid proximity to excessive heat.

Adapter Power In: Your adapter requires a small 12VDC power supply. Connect it to the same switched AC power line as your light fixture. Connect the red(+) and black(-) wires of your adapter to the respective + and - output terminals of the power supply. **Do not connect your adapter directly to the AC power line!**

Tip: A MEAN WELL model APV-8-12 power supply has been found to work well. It is inexpensive and has a convenient form factor.

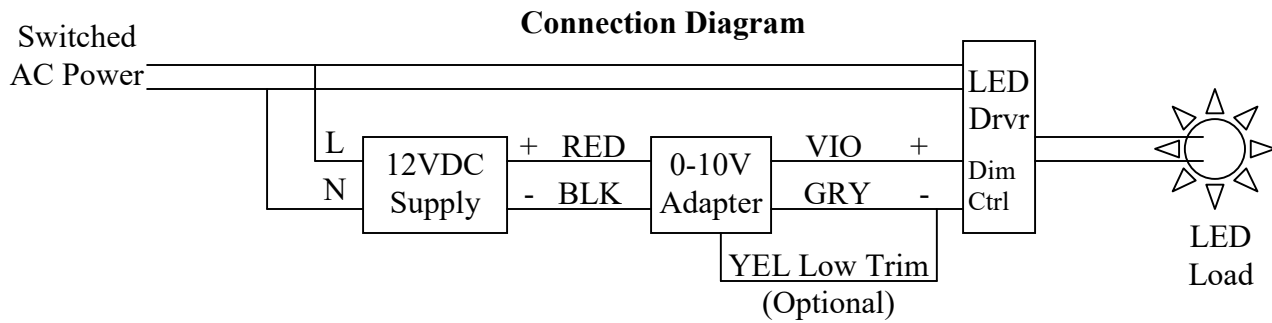

0-10V Control Signal Out: Connect the violet(+) and gray(-) wires of your adapter to the respective + and - 0-10V Control terminals of your fixture(s). In most cases the fixture 0-10V Control connections will be wires of like colors. Consult your fixture documentation to be sure.

Tip: When connecting multiple fixtures to your adapter's 0-10V terminals, assure total control current does not exceed 1000 mA. Most fixtures require less than 50 mA. Check fixture data.

Adapter Low Trim Sense: Connect the yellow wire to the gray wire of your adapter to enable the Low Trim feature. (See Low Trim discussion below.) Leave the yellow wire disconnected for maximum dimming range.

OPERATION

Blink your power switch off briefly (about 1 second) to activate a blink response, depending on the current state of your fixture:

State	Blink Response
Full Bright -OR- Steady after brightening	Begin gradual dimming
Gradually changing	Stop changing, remain steady
Full Dim -OR- Steady after dimming	Begin gradual brightening

When you switch power on after a long period, lights return to their previous state.

Energy Saving Preset: Preset a brightness level for regular energy savings. A setting perceived as half bright uses about 75% less energy.

Reset Factory Defaults: To operate the reset function:

- 1) Switch lights off and leave them off for at least 10 seconds
- 2) Blink lights on about one second
- 3) After blink, leave lights off another 10 seconds

When you switch power back on, lights should come on steady at full brightness. This is useful if you are operating several Blink'n'Dim Adapters from a single switch. After reset, all fixtures should dim and brighten simultaneously.

The reset function may also be used to adjust the Low Trim setting.

SETTING AND USING LOW TRIM

The Low Trim feature helps optimize your adapter for operation with your particular light fixture. Fixtures with 0-10V dimming control do not all work the same at lower light levels. Commonly there is a minimum level below which further smooth dimming is not possible. Attempts to dim below that level may have no effect, or may cause lights to turn completely off. Either way, there is a "dead zone" in which control voltage changes do not produce corresponding brightness changes.

Low Trim eliminates the "dead zone" by setting the minimum value of the 0-10V control signal to the lowest value to which the fixture can respond.

If your fixture is capable of dimming to very low levels, leave the Low Trim input (yellow wire) disconnected. This will permit the 0-10V control signal to reach a minimum level of about 0.04 volts.

Factory Default Low Trim: If your fixture is advertised as dimmable to 10%, or compatible with 1-10V control, connect the Low Trim input to the gray wire before ever turning power on. 10% is the factory default Low Trim setting. Your control signal will be limited to a range of 1-10V.

To set a Low Trim level other than 10%:

- 1) Power on with the Low Trim input (yellow wire) disconnected
- 2) Adjust brightness to the desired Low Trim level (40% max)
- 3) Turn off power
- 4) Connect the Low Trim input (yellow wire) to the gray wire
- 5) Perform a reset function

When lights are turned back on, they should come on at full brightness. When fully dimmed, they should stop at the Low Trim level you set in step 2 above, or 40% if you attempted to set a higher level.

To restore Low Trim level to factory default 10%:

- 1) Turn off power
- 2) Disconnect the Low Trim input (yellow wire)
- 3) Perform a reset function and leave power off
- 4) Connect the Low Trim input (yellow wire) to the gray wire

When lights are turned back on, they should come on at full brightness. When fully dimmed, they should stop at 10%.

Note: On some fixtures, it is possible to set a Low Trim level too low for lights to turn on at all after being switched off. In this case, blink power off (even though lights do not blink) to begin brightening. After lights come on, you may be able to dim to the Low Trim level and have them remain on.

BLINK INDICATOR

A green LED glows when your adapter is detecting 12V power. This indicator should light promptly when you switch power on, and go out promptly when you switch power off. A significant delay indicates your power supply has too much capacity and is storing energy internally. Power supplies rated 1000 mA capacity or less are recommended. Your adapter uses less than 80 mA. Blink signals must be long enough to visibly turn off the blink indicator. Use a small capacity power supply to assure Blink'n'Dim commands are easily recognized. As a workaround, a resistor connected across the 12V power supply terminals can help discharge stored energy more rapidly. For example, a 120 ohm resistor will drain an additional 100 mA, and dissipate 1.2 Watts of power. This resistor should be rated for at least 2.4 watts to avoid overheating.

CUSTOMER ASSISTANCE

On our web site, Responsivled.com, you'll find a downloadable copy of this guide and other consumer product information. You may use the contact form to communicate questions or comments.

SWITCH LABELS

Blink'n'Dim labels indicate switches with dimming control. If you need more, you can print them on adhesive backed label paper, or attach with double sided tape.



Tip: Scrape adhesive backing from a small corner with a knife blade. The label can be peeled away easily.